



potenza



High
Air flow



Energy
Saving



Rigid
Structure



Easy
Installation



PGH Series

Exhaust Fan



Scan for more
information
potenza2u.com

Reliability Driven by Innovation



PGH Series

Exhaust Fan



» FEATURES

- 100% Copper Wire Motor
- Large Air Flow for Maximum Ventilation
- High Quality Bearing
- High Quality Structure with long service life

» SPECIFICATION

Model	Size (inch)	Power	Voltage (V)	Air Flow (m ³ /min)	Speed (rpm)	Noise (dB)	Weight (kg)
PGH-30-12	12	100W	240	30	1400	69	6.5
PGH-40-16	16	165W		48		74	8.5
PGH-50-18	18	230W		93		78	19.5
PGH-60-24	24	700W	415	196	960	80	21
PGHT-60-24							
PGH-60-24-6P		330W	240	105	76		

» DIMENSION

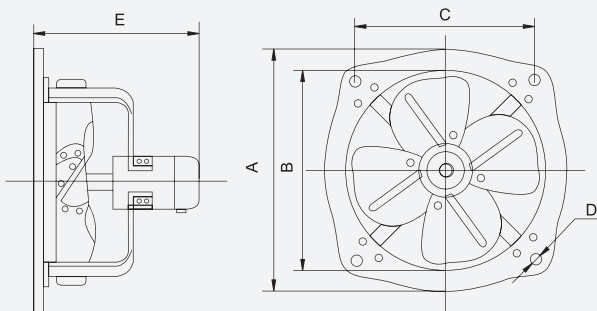

Model	A	B	C	D	E
PGH-30-12	390	325	308	8.5	195
PGH-40-16	483	417	367	8.5	255
PGH-50-18	600	520	470	10.5	305
PGH-60-24	700	623	585	12	370
PGHT-60-24	700	623	585	12	370